

D

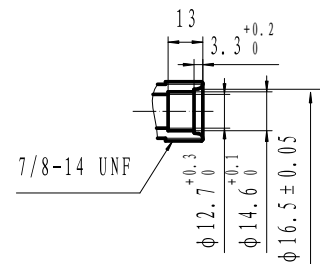

S

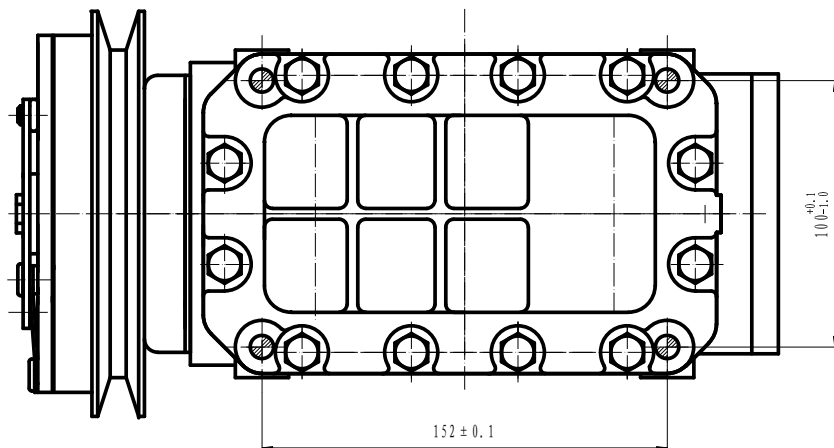

- COMPRESSOR:
1. CYLINDER: 3xφ49x40;
 2. DISPLACEMENT: 226.3cc;
 3. WEIGHT: 10.6kg;
 4. OPERATING SPEED: 4200rpm (Max 5000rpm);
 5. DIRECTION OF ROTATION: CLOCK WISE;
 6. LEAKAGE TEST: ADDITIONAL TABLE

ITEM	HIGH PRESSURE SIDE	LOW PRESSURE SIDE
AIRPROOF PRESSURE	2.9 (30)	1.5 (15)
RESISTANT PRESSURE	4.4 (45)	2.2 (22.5)

7. GAS LEAK: < 30g/year

MAGNETIC CLUTCH

1. RATED VOLTAGE: DC 24V;
2. SHAPE OF THE BELT: 1B;
3. STATIC TORSTON: ABOVE 68.6N.m;
4. WATTAGE: 47W;
5. WEIGHT: 4Kg.

NOTE FOR COMPRESSOR INSTALLATION:

1. INCLINATION AT INSTALLATION SHOULD BE < 15° IN LATERAL DIRECTION; < 5° FOR FRONT LIFTING; AND NO LIFTING FOR REAR SIDE;
2. DURING TRANSPORTATION, COMPRESSOR SHOULD NOT BE INCLINED BY 45° IN BOTH LATERAL AND LONGITUDINAL DIRECTIONS; BEFORE INSTALLATION, COMPRESSOR SHOULD BE PLACED HORIZONTALLY FOR MORE THAN 10 MINUTES;
3. REQUIREMENTS FOR THE BOLT TORSTONS:
FIXED BRACKET BOLT: 36-50N.m
FIXED LINKER BOLT: 20-24N.m

				HCP-23		HZL	
设计	审核	工艺	校对	日期	年月日	COMP ASSEMBLY	
版次	日期	2006.12.28	版数	1			
审核			比例	1:1			
工艺			共	张	第	张	305160-3500