

低压接口 1(1/16)'-14UNF

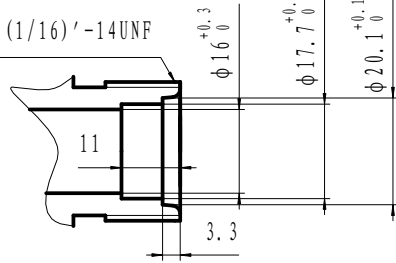

高压接口 7/8'-14UNF

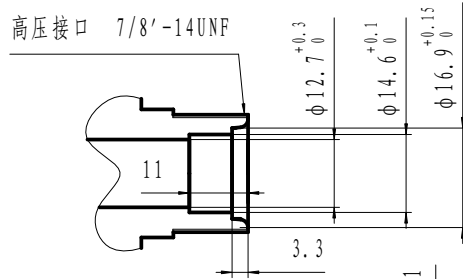

保护管 L = 150

300⁺²⁰₀

线总长

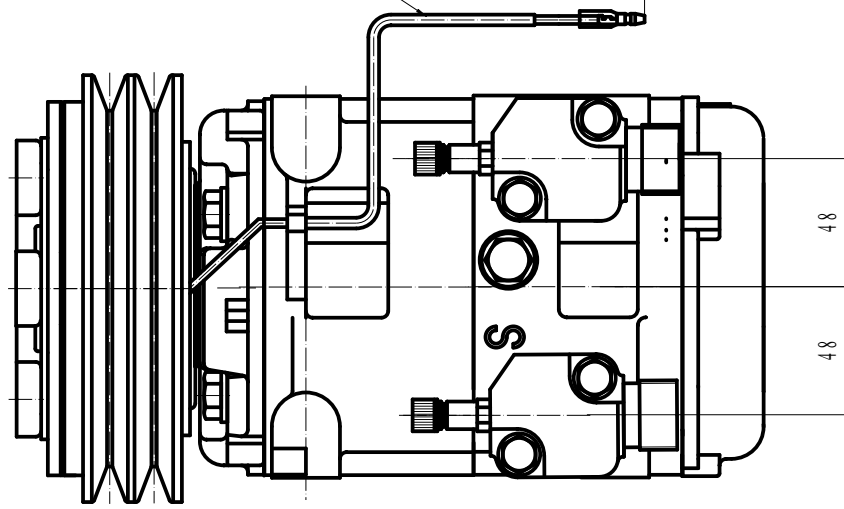

COMPRESSOR ASSY:

1. OPERATING SPEED: 700~5000r/min (MAXIMUM SPEED 6000r/min)
2. DIRECTION OF ROTATION: CLOCK WISE
3. WEIGHT: 15.5Kg
4. REFRIGERANT: HFC-134a
5. LUBRICANT: PAG 500⁺cm³
6. WEIGHT: 10.6kg (WITHOUT OIL)

MAGNETIC CLUTCH:

1. RATED VOLTAGE: DC 24V
2. SHAPE OF THE BELT: 2B
3. STATIC TORSION: ABOVE 78N.m (8kgf.m)
4. WATTAGE: 48W (DC24V 2.0A) (25° C)
- MINIMUM ATTRACTING VOLTAGE: BELOW 9V (90° C)
5. THERMAL RESISTANCE: AT 100° C, DC30V ELECTRICITY SUCCESSIVELY
6. WEIGHT: 5.5kg

COMPRESSOR:

1. MODEL: HCS-33
2. CYLINDER: 10-φ37X30.7
3. DISPLACEMENT: 330cm³/rev
4. LEAKAGE TEST: ADDITIONAL TABLE
5. GAS LEAK: 30g/y

NOTE FOR COMPRESSOR INSTALLATION:

1. INCLINATION AT INSTALLATION SHOULD BE < 15° IN LATERAL DIRECTION; < 5° FOR FRONT LIFTING; AND NO LIFTING FOR BACKSIDE;
2. DURING TRANSPORTATION, COMPRESSOR SHOULD NOT BE INCLINED BY 45° IN BOTH LATERAL AND LONGITUDINAL DIRECTIONS; BEFORE INSTALLATION, COMPRESSOR SHOULD BE PLACED HORIZONTALLY FOR MORE THAN 10 MINUTES;
3. REQUIREMENTS FOR THE BOLT TORSIONS:
FIXED BRACKET BOLT: 36-50N.M
FIXED LINKER BOLT: 20-24N.M

ITEM	UNIT	HIGH PRESSURE SIDE	LOW PRESSURE SIDE
AIRPROOF PRESSURE	MPa (Kg ^f /cm ² G)	2.9 (30)	1.5 (15)
RESISTANT PRESSURE	MPa (Kg ^f /cm ² G)	4.4 (45)	2.2 (22.5)

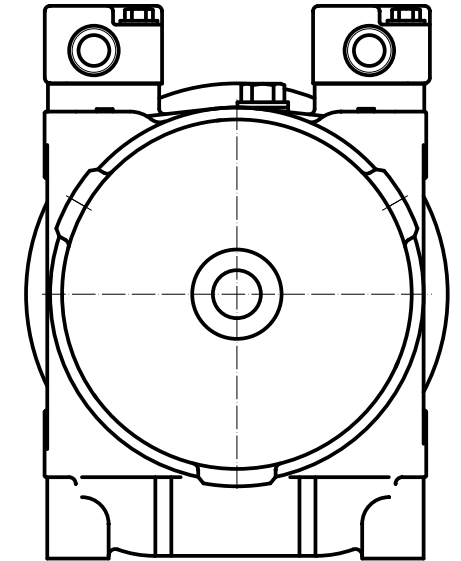
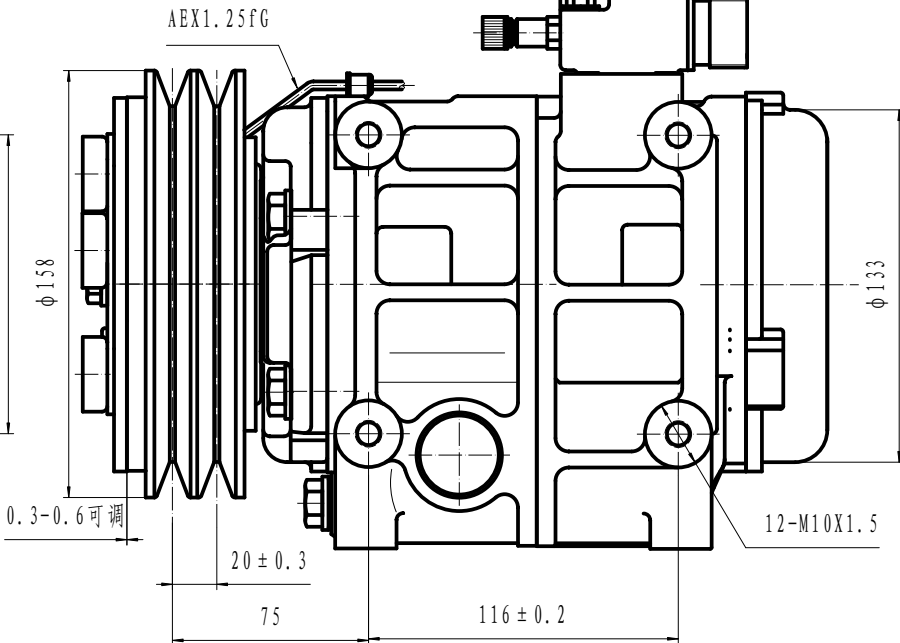
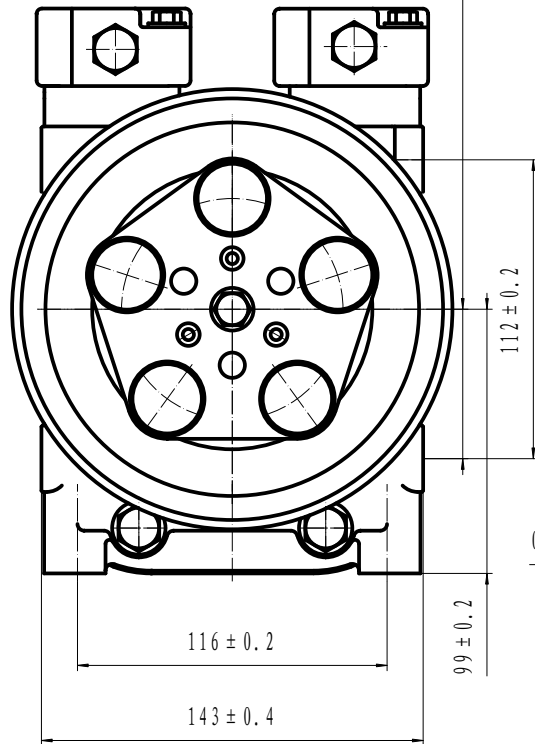

HCS-33										重庆华之龙汽车制冷设备有限公司	
总装图										1:1	
305160-8300											